

High Efficiency & Dynamic Movement System

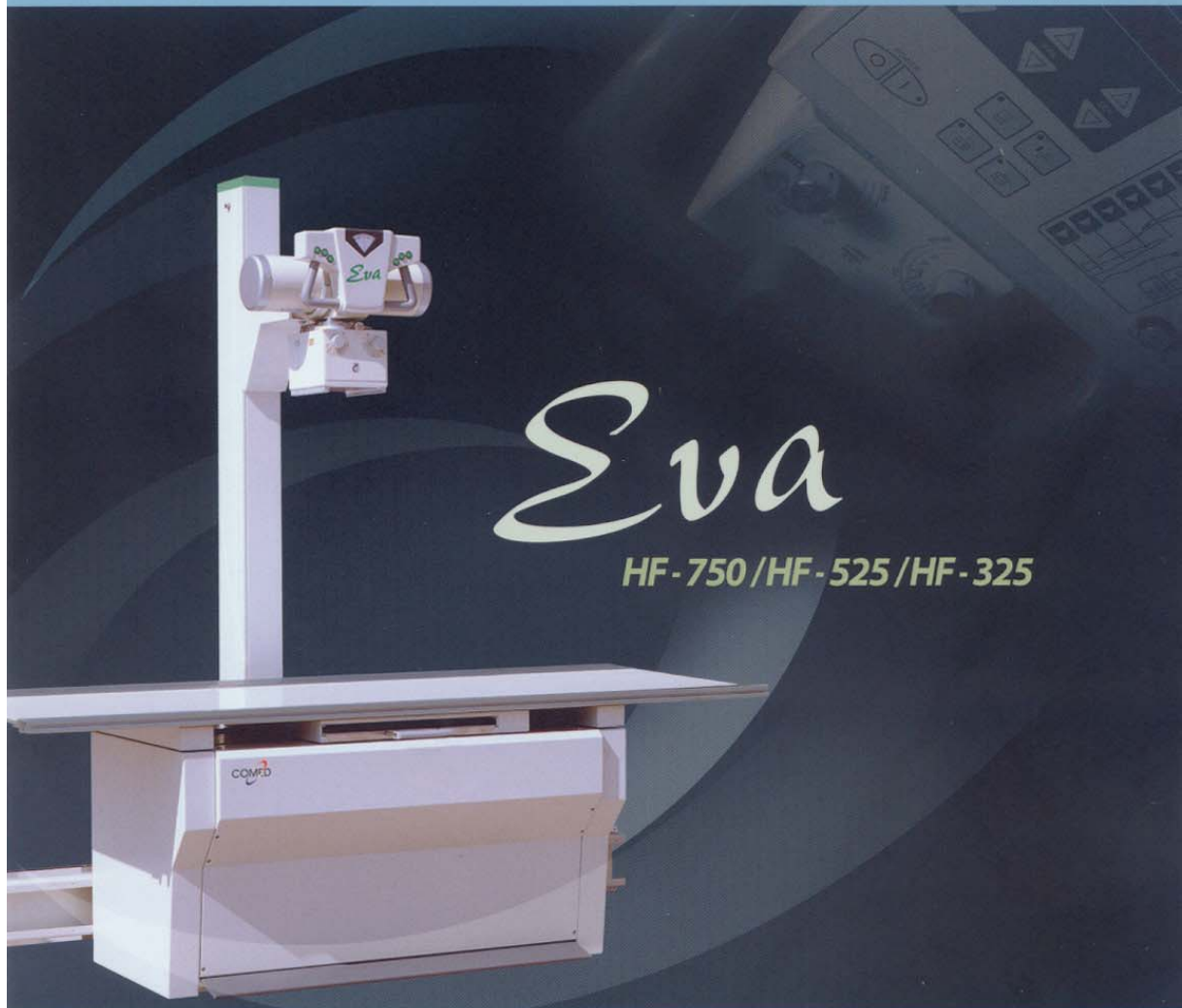

High Frequency Inverter Radiography X-ray System

Creative & Innovative Medical System



Eva

Series

HF-750 / HF-525 / HF-325

High Efficiency & Dynamic movement System



COMPACTABLE SYSTEM

New concept of high performance general radiographic system. One-body system of X-ray control system and high voltage generator, easy to move and can be installed in the small area.

EFFICIENCY

Multiple-positioned radiography function is more comfortable to the patient. User-friendly and a small radius of action is one of the good points. Easy to lateral radiography as tube arm revolves 180 and table top is flat.

INNOVATIVE FUNCTION

Multiple-positioned radiography function is more comfortable to the patient. User-friendly and a small radius of action is one of the good points. Easy to lateral radiography as tube arm revolves 180 and table top is flat.

Innovative, Compact and Powerful

High Frequency Inverter Radiography X-ray System

Powerful Invert Generator System

Powerful System

High frequency type radiography system with versatility and high performance. Versatile and excellent Radiography system for whole parts of body.

Programmable user control

All system is controlled by microprocessor program. It shows its best ability as a circuit-integrated system.

Analysis

System-Self-Diagnosis and Self-diagnostic circuitry standard on each unit. Equipped with closed loop for X-ray tube current as well as kVp, minimizing potential errors and need for re-adjustments.

Superior Imaging

- Technologically Advanced High Performance Imaging
- Expanded Dynamic Range
- Shorter exposure time, less radiation dose improved image quality
- High Frequency Generator

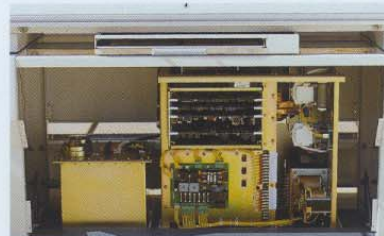

Simple Design & User Convenience

New Operation Console

- New concept of high performance operation console system. More consideration for use.



Multiple Microprocessor

- Controlled by multiple microprocessors assuring consistent and repeated X-ray operation. service mode is used to calibrate the generator.

Display panel with LCD

- **LCD has twice wide windows** ■ It is easy to use for users

Radiography condition is basically set up

- Convenient control system with APR option. Programmed into the best one, so it is possible to radiate with simple operation. It can be changed by users.



Possible long-distance control

- Connected X-ray control system and display panel with cable.

Versatile Functioned System



Ceiling Suspended

This is a rigid, heavy work loads and stable ceiling tube support system. This has been designed to provide effortless positioning over an extension area for all types of general radiography and procedures.

Wall Bucky

The Bucky stand is designed for general purpose radiographic exposures for chest, thorax spinal and skull of standing patient. The unit can be wall mounted or freestanding near to a bucky table.

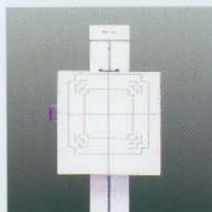

PSU

It is possible that radiate a x-ray with general sources of electricity, and can be used as a MOBILE CARE SYSTEM (option).



Dimensions

- EVA-HF 750
- EVA-HF 525
- EVA-HF 325

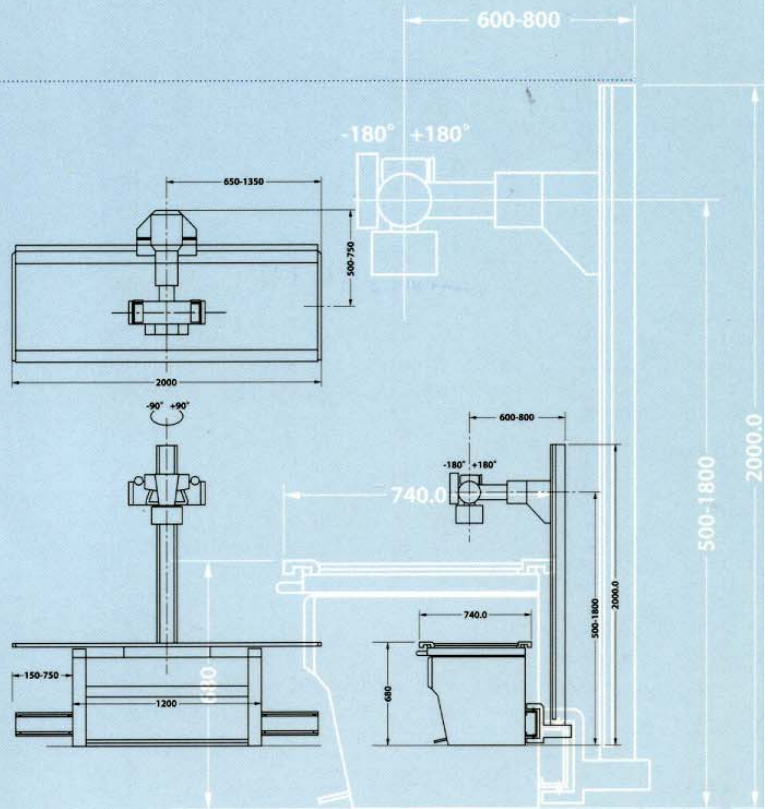

Dimensions

- Ceiling Suspended (KM-CS)

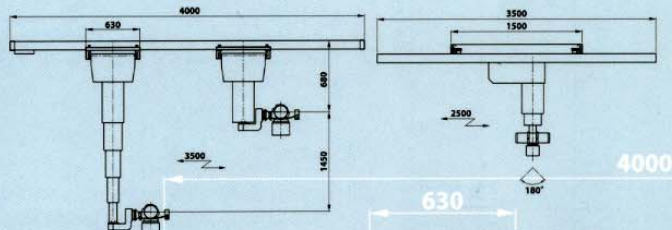

- Well Bucky Stand (KM-WB)

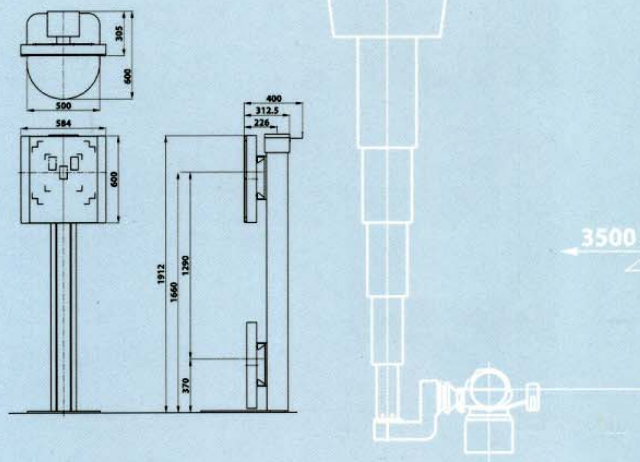

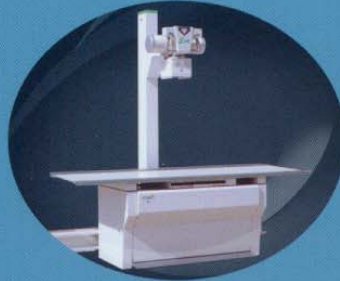

Specifications

	ITEM	EVA-HF 325	EVA-HF 525	EVA-HF 750
X-RAY TUBE	MODEL	E7239X	E7239X	VARIAN or TOSHIBA
	FOCAL SPOT	1.0 / 2.0	1.0 / 2.0	0.6 / 1.2 or 1.0 / 2.0
	OPERATING VOLTAGE	40-125KVP (300mA)	40-125KVP (500mA)	40-150KVP (700mA)
	TARGET ANGLE	16°	16°	16°
	ANODE HEAT STORAGE	140,000 HU	140,000 HU	300,000 HU
HI-TRANS	METHODE	INVERTER (40kHz)	INVERTER (40kHz)	INVERTER (40kHz)
	MAX VOLTAGE	125kVp	125kVp	150kVp
	MAX CURRENT	300mA	500mA	700mA
	POWER	37.5kW	40kW	50kW
CONTROLLER	KVP STEP	1 kVp (40-125kVp)	1 kVp (40-125kVp)	1 kVp (40-150kVp)
	TIME STEP	1msec-5sec	1msec-5sec	1msec-5sec
	mA STEP	25, 50, 75, 100, 150, 200, 250, 300mA	25, 50, 75, 100, 150, 200, 250, 300, 400, 500mA	50, 100, 200, 300, 400, 500, 600, 700mA
	TYPE	High Frequency Inverter	High Frequency Inverter	High Frequency Inverter
COLLIMATOR	METHODE	MANUAL	MANUAL	MANUAL
	MAX VOLTAGE	150KV	150KV	150KV
	MAX WINDOWS	35cm x 35cm (SID 65cm)	35cm x 35cm (SID 65cm)	35cm x 35cm (SID 65cm)
	MIN WINDOWS	5cm x 5cm (SID 100cm)	5cm x 5cm (SID 100cm)	5cm x 5cm (SID 100cm)
GENERAL	ELECTRICAL	1∅ 220V 37.5KW	1∅ 220V 40KW	3∅ 380V 50KW
	USE CASSETTE MAX SIZE	14" x 17"	14" x 17"	14" x 17"
	INDICATOR	LCD, programable APR	LCD, programable APR	LCD, programable APR

Distributor